

# ProSpot 150 *L* X

 **coemar**

1° release: november 2001

# Index

<b>1. Packaging</b>	Pag. 40
<b>2. Transportation</b>	.. 40
<b>3. Important safety information</b>	.. 41
<b>4. Lamp: installation and replacement</b>	.. 42
<b>5. Operating voltage and frequency</b>	.. 44
<b>6. Installation</b>	.. 45
<b>7. Mains connection</b>	.. 47
<b>8. Signal connection</b>	.. 48
<b>8.1. Automated operation - "solo"</b>	.. 48
<b>8.2. Operation via DMX 512</b>	.. 48
<b>8.3. Synchronising multiple ProSpot 150 LX fixtures without DMX signal</b>	.. 49
<b>8.4. Synchronising multiple ProSpot 150 LX fixtures via 6 channels DMX signal</b>	.. 50
<b>9. Powering up</b>	.. 51
<b>10. Display panel functions</b>	.. 52
<b>10.1. Operating modes "Mode"</b>	.. 52
<b>10.2. Functions "Func"</b>	.. 53
<b>10.3. Parameters and testing "MEAS"</b>	.. 54
<b>10.4. Quick guide to menu navigation</b>	.. 55
<b>10.5. Rapid scrolling</b>	.. 55
<b>11. Setting the ProSpot 150 LX to operate automatically</b>	.. 56
<b>12. Setting the ProSpot 150 LX to operate via DMX 512</b>	.. 58
<b>12.1. DMX 512 addressing</b>	.. 58
<b>12.2. DMX functions</b>	.. 59
<b>13. Setting multiple ProSpot 150 LX fixtures to operate in synchronised mode without DMX signal</b>	.. 60
<b>13.1. "Master" unit</b>	.. 60
<b>13.2. "Slave" units</b>	.. 61
<b>14. Setting multiple ProSpot 150 LX fixtures to operate in synchronised mode using 6 channels of DMX</b>	.. 61
<b>15. Recording programs to the internal memory of the ProSpot 150 LX</b>	.. 63
<b>15.1 Addressing</b>	.. 63
<b>15.2 DMX programming channels</b>	.. 63
<b>15.3 Programming example</b>	.. 64
<b>16. Aligning the lamp in the optical path</b>	.. 65
<b>17. Turning on the ProSpot 150 LX without articulated movement</b>	.. 66
<b>18. Resetting the electronic counter</b>	.. 66
<b>19. Automatic position realignment</b>	.. 66
<b>20. Interchanging gobos</b>	.. 67
<b>21. Altering the operating voltage and frequency (Reserved for technical staff only)</b>	.. 69
<b>21.1. Selecting the operating voltage on the autotransformer</b>	.. 69
<b>21.2. Selecting the operating frequency on the power supply of ProSpot 150 LX</b>	.. 70
<b>22. Thermal protection</b>	.. 70
<b>23. Maintenance</b>	.. 71
<b>24. Electronic motor alignment</b>	.. 72
<b>25. Error messages</b>	.. 73
<b>26. Spare parts</b>	.. 73

Congratulations on having purchased a **coemar** product. You have assured yourself of a fixture of the highest quality, both in componentry and in the technology used. We renew our invitation to you to complete the service information on the previous page, to expedite any request for service information or spares (in case of problems encountered either during, or subsequent to, installation). This information will assist in providing prompt and accurate advice from your **coemar** service centre.

## **1. Packaging**

Following the instructions and procedures outlined in this manual will ensure the maximum efficiency of this product for years to come.

Open the packaging and ensure that no part of the equipment has suffered damage in transit. In case of damage to the equipment, contact your carrier immediately by telephone or fax, following this with formal notification in writing.

### **packing list**

Ensure the packaging contains:

**1** ProSpot 150 LX

**1** instruction manual

**1** 5 AT fuse (for 115V connection or 3A T for 230V connection)

## **2. Transportation**

The ProSpot 150 LX should be transported in its original packaging or in a **coemar** approved flight case.

During transportation, the packaging or flight case should ensure no articulated movement of the ProSpot 150 LX head. Failure to do so may result in damage to the unit.

### 3. Important safety information

#### Fire prevention:

1. ProSpot 150 LX utilises a Philips CDM-SA/T 150W lamp or equivalent; the use of any other lamp is not recommended and will null and void the fixtures warranty.
2. Never locate the fixture on any flammable surface.
3. Minimum distance from flammable materials: 0,5 m.
4. Minimum distance from the closest illuminable surface: 2 m.
5. Replace any blown or damaged fuses only with those of identical values. Refer to the schematic diagram if there is any doubt.
6. Connect the projector to mains power via a thermal magnetic circuit breaker.

#### Prevention of electric shock:

1. High voltage is present in the internals of the unit. Isolate the projector from mains supply prior to performing any function which involves touching the internals of the unit, including lamp replacement.
2. For mains connection, adhere strictly to the guidelines outlined in section 7 of this manual.
3. The level of technology inherent in the ProSpot 150 LX requires the use of specialised personnel for all service applications; refer all work to your authorised **coemar** service centre.
4. A good earth connection is essential for proper functioning of the projector.  
Never operate the unit without proper earth connection.
5. The fixture should never be located in an exposed position, or in areas of extreme humidity. A steady supply of circulating air is essential.

#### Protection against ultraviolet radiation

1. Never turn on the lamp if any of the lenses, filters, or the housing is damaged; their respective functions will only operate efficiently if they are in perfect working order.
2. Never look directly into the lamp when it is operating.

#### Safety:

1. The projector should always be installed with bolts, clamps, and other fixings which are suitably rated to support the weight of the unit.
2. Always use a secondary safety chain of a suitable rating to sustain the weight of the unit in case of the failure of the primary fixing point.
3. The external surface of the unit, at various points, may exceed 80°C. Never handle the unit until at least 10 minutes have elapsed since the lamp was turned off.
4. Never install the fixture where unauthorised and untrained personnel may tamper with it.
5. Always replace the lamp if any physical damage is evident.
6. Never install the fixture in an enclosed area lacking sufficient air flow; the ambient temperature should not exceed 35°C.
7. A hot lamp may explode. always wait for at least 10 minutes to elapse after the unit has been turned off prior to attempting to replace the lamp.  
Always wear suitable hand protection when handling the lamp.

#### Protection rating of the body against liquids and solids:

1. The fixture is classified as an ordinary fixture, its protection rating against liquids and solids is IP 20.

## 4. Lamp: installation and replacement

ProSpot 150 LX utilises a Philips CDM-SA/T 150W, mastercolour or equivalent.

The lamp is available from your authorised **coemar sales agent**:

<b>coemar code</b>	<b>105500</b>
power	150 w
luminous flux	12.900 lm
colour temperature	4.200° K
base	G 12
approximate lamp life	6000 hours

### Attention

Turn off the power prior to opening up the unit.

The fixtures internal temperature may reach 150° C after 5 minutes, with a maximum peak of 350° C. Ensure the lamp is cold prior to attempting removal. The fixture should be allowed to stand and cool for 10 minutes prior to its removal.

CDM lamps are part of the mercury vapour family of discharge lamps and must be handled with great care. the lamp operates at high pressure, and the slight risk of explosion of the lamp exists if operated over its recommended life.

We recommend, therefore, that the lamp be replaced within the manufacturers specified lamp life.

### installing the lamp

1) Using a Philips head screwdriver, remove the 2 screws (A) which affix the lamp assembly to the rear of the projector.



2) Remove the lamp assembly (B).



3) Locate the lampholder (C)

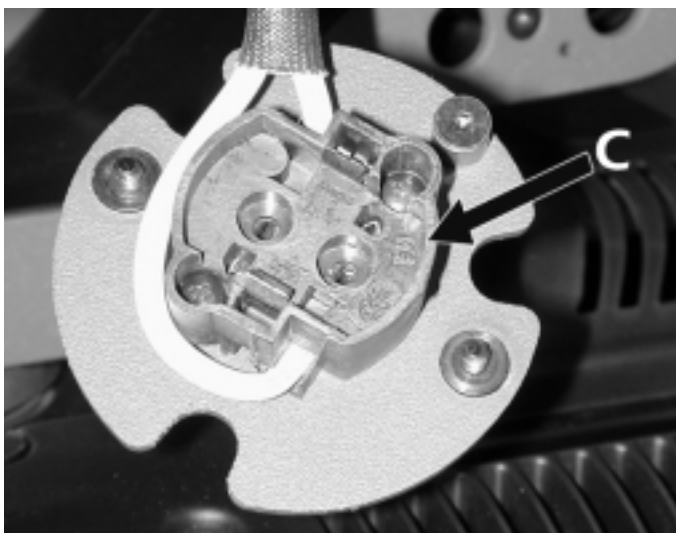

- 4) Insert the lamp. The lamp used is manufactured from quartz glass and should be handled with care; always adhere to the instructions supplied in the lamp's packaging. The G 12 lampholder is symmetrical in construction. DO NOT USE UNDUE FORCE. In case of difficulty, re-read the instructions and repeat the procedure.

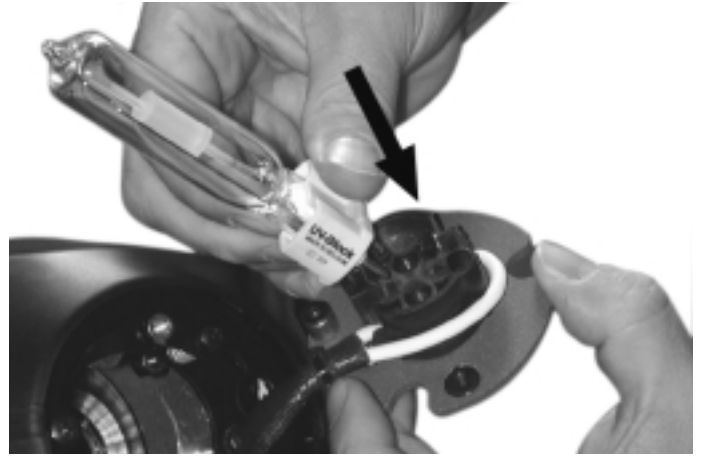

- 5) Replace the lamp assembly (**B**) into its original position and replace and retighten the two screws (**A**) which were previously removed.

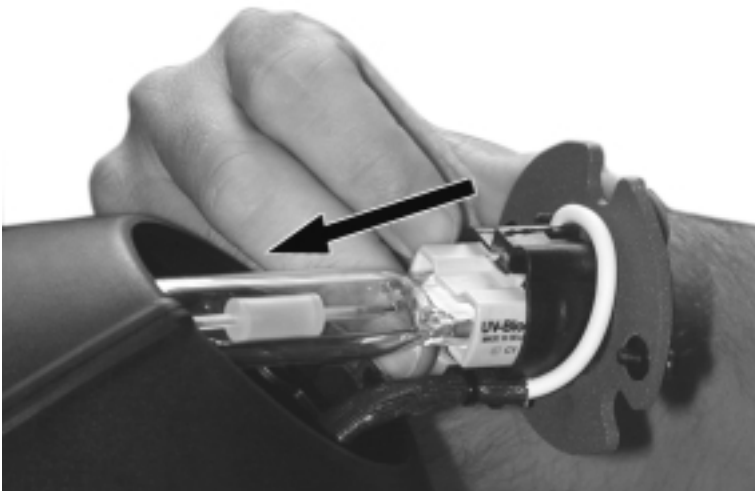

**Attention:** we recommend that the lamp be realigned in the optical train of the unit to avoid overheating of the dichroic filters and other internal components of the unit. refer to section 16 for instructions about this procedure.

## 5. Operating voltage and frequency

The projector may operate at voltages of 100, 115, 208, 230 or 240V .at 50 or 60 Hz; **coemar** factory presets (barring specific requests), a voltage of 230v and a frequency of 50 Hz. This preset is indicated on the sticker located on the base of the projector, as indicated in the following diagram.

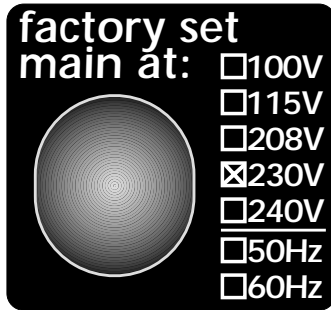

If the specified voltage and frequency do not match those of the country in which you are operating, follow the instructions in section **21. Altering the operating voltage and frequency**

**Incorrect voltage and frequency selection will detrimentally affect the operation of the projector.**

## 6. Installation

### mounting

ProSpot 150 LX may be installed in any position.

The structure from which the unit is hung should be of sufficient rating to hold the weight of the unit, as should any clamps used to hand the unit.

The structure should be sufficiently rigid so as not to move or shake whilst the ProSpot 150 LX moves during its operation.

The 2 Ø14 mm mounting holes in the base (**A**) allow the unit to be mounted using appropriate clamps, or other means, on suitable structures.

Never install the unit where unauthorised or untrained personnel may tamper with the projector.

### safety chain

The use of a safety chain affixed to the ProSpot 150 LX and to the primary suspension point is highly recommended. Attach the chain to the ring (**B**) located at the rear of the base of the unit, and to the primary suspension point to protect against the accidental failure of the units main suspension point.

If using an after-market safety chain not manufactured by **coemar**, ensure that it is of sufficient rating to hold the weight of the unit.

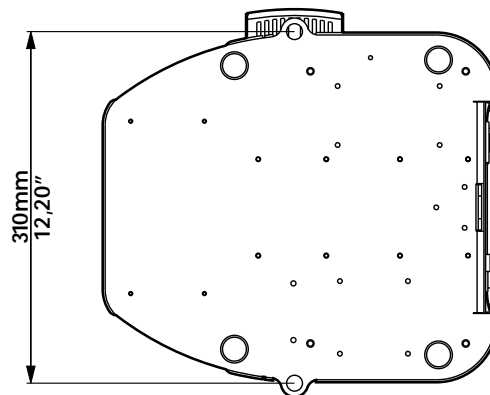
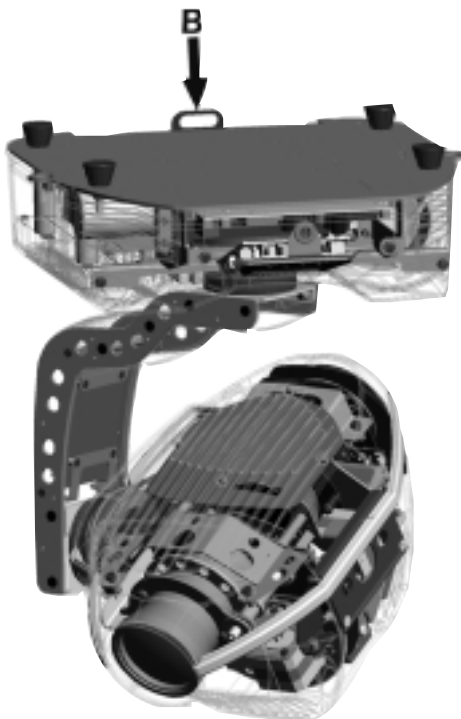
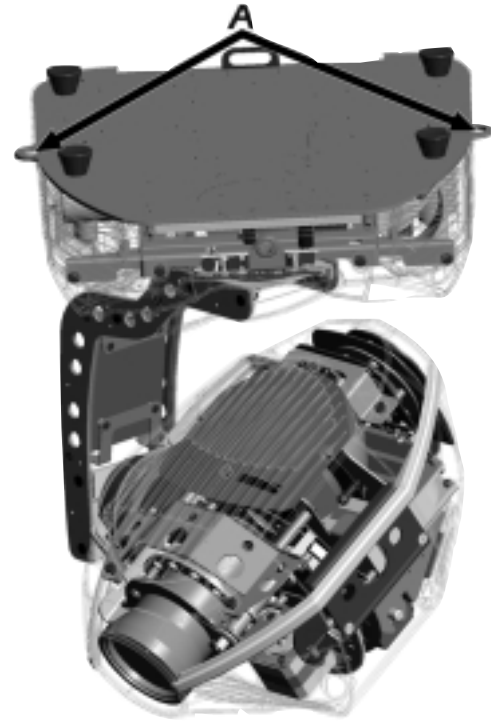

### movement

**DO NOT** obstruct the articulated movement of the projector by placing objects in the path of its moving components.

**protection against liquids**

The projector contains electric and electronic components that must not come into contact with water, oil, or any other liquid.

**protection against dust**

Dust and dirt can shorten the life of the unit appreciably; ProSpot 150 LX has not specific protection devices against dust and dirt and regular cleaning is recommended to avoid any build up within the projector.

**risk of fire**

Each fixture produces heat and must be installed in a well-ventilated position. The minimum recommended distance from flammable material is: 0.5m. Minimum distance from the object being illuminated is: 2 m.

**forced ventilation**

There are several ventilation openings in the projector body and the base for air flow to occur. These should never be obstructed under any circumstances!

Should this occur, the result may be overheating of the unit which will seriously affect the proper operation of the ProSpot 150 LX.

**ambient temperature**

The projector must be installed in a well-ventilated area; the ambient temperature should not exceed 35°C.

## 7. Mains connection

### cabling

The mains cable provided is thermally resistant, complying to the most recent international standards.

**NB:** In case of cable replacement, similar cable with comparable thermal resistant qualities must be used exclusively (cable 3x1.5  $\varnothing$  external 8 mm, rated 300/500V, tested to 2KV, operating temperature -40° +180°).

### mains connection

ProSpot 150 LX can operate at voltages from 100V-115V-208V-230V-240V at 50 or 60Hz (operating voltage and frequency can be selected as described in section 5 of this manual). Prior to connecting the unit to your mains supply, ensure that the model in your possession correctly matches the mains supply available to you.

For connection purposes, ensure your plug is of a suitable rating: 1,2 amps at 230v, and 2,2 amps at 115V.

Locate the mains cable which exits the base of the unit and connect as shown below:

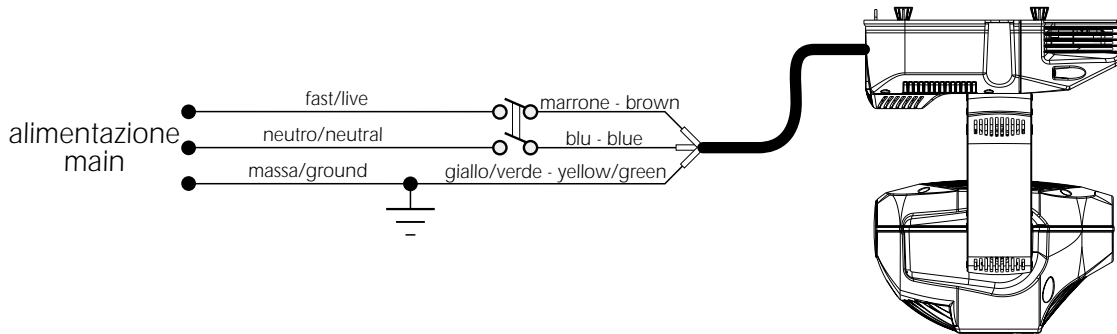

### protection

The use of a thermal magnetic circuit breaker is recommended for each ProSpot 150 LX.

A good earth connection is essential for the correct operation of the fixture. Strict adherence to regulatory norms is strongly recommended.

## 8. Signal connection

ProSpot 150 LX may operate in one of 4 different modes, which may require varied cable arrangements:

### 8.1. Automated operation "solo"

### 8.2. Operation via DMX 512

### 8.3. Synchronising multiple ProSpot 150 LX fixtures without DMX

### 8.4. Synchronising multiple ProSpot 150 LX fixtures via 6 channels of DMX

Depending upon which mode you wish to operate in, you should consult the appropriate instructions below:

### 8.1. Automated operation "solo"

ProSpot 150 LX may operate independently, executing pre-recorded programs which cause it to change colours, gobos, and positions (see "Recording programs to the internal memory") activated via the +/-/menu/enter, without the need for an external control signal.

In this mode of operation, there is no connection to the unit via the XLR 3 sockets labeled DMX 512 in and out.

### 8.2. Operation via DMX 512

Control signal is digital, and is transmitted via two pair screened  $\varnothing 0.5\text{mm}$  cable.

Connection is serial, utilising the XLR 3 male and female sockets located on the base of the ProSpot 150 LX, labeled DMX 512.

If using a controller which output signal via an XLR 5 (5 pin) socket, do not use pins 4 and 5, leaving them unconnected.

Pin connections conform to the international standard:

pin 1= screening 0 volt	pin 4= not connected
pin 2= data -	pin 5= not connected
pin 3= data +	

### Connection using a 3 pin XLR 3

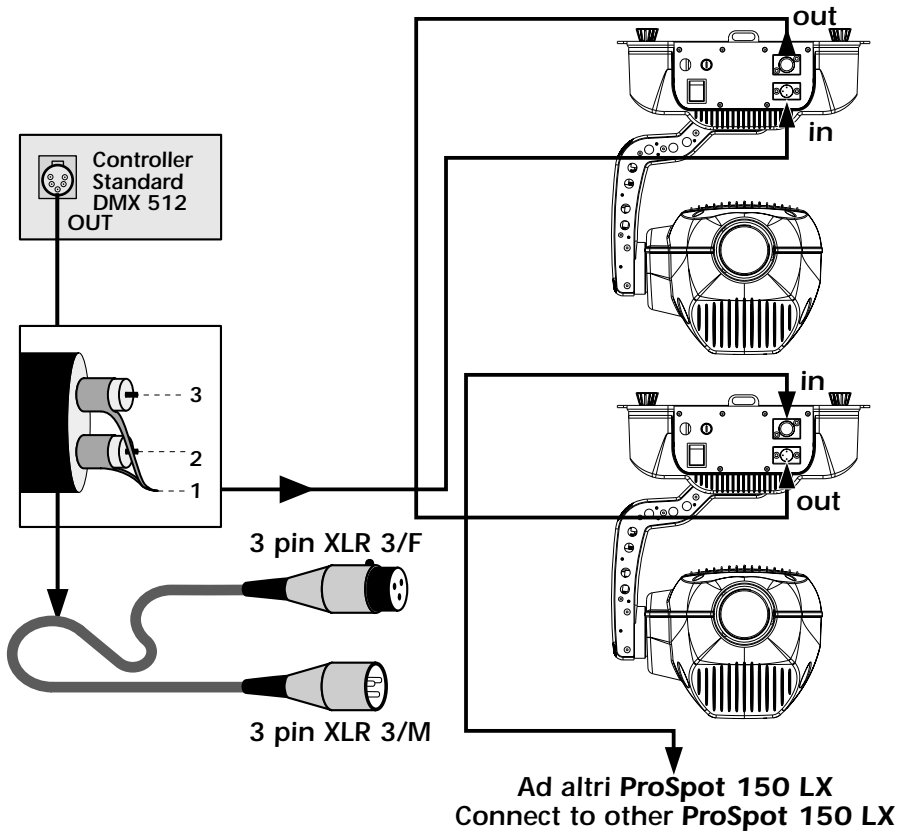

Ensure that all data conductors are isolated from one another and the metal housing of the connector.

**Note: the housing of the cannon XLR connectors being used must be isolated.**

### 8.3. Synchronising multiple ProSpot 150 LX fixtures without DMX

The output of multiple ProSpot 150 LX units may be synchronised without using an incoming DMX 512 signal, by utilising the fixtures synchronising signal and internally stored programs.

Multiple ProSpot 150 LX fixtures may be utilised, operating in sequence and controlled by a MASTER fixture controlling multiple SLAVE units.

Selecting which ProSpot 150 LX is to be utilised as the MASTER is simply a matter of which fixture allows easiest access to the LED display and menu buttons:

Connect the XLR3 output of the master unit to the XLR input of the first slave unit. The XLR output of the first slave is then connected to the XLR input of the second slave, and so on up to a maximum total of 32 projectors. If connecting more than 10 units, we recommend the use of a suitable opto-isolated connecting unit to amplify the signal as required.

Pin connections conform to the international standard:

pin 1= gnd  
pin 2= data -  
pin 3= data +

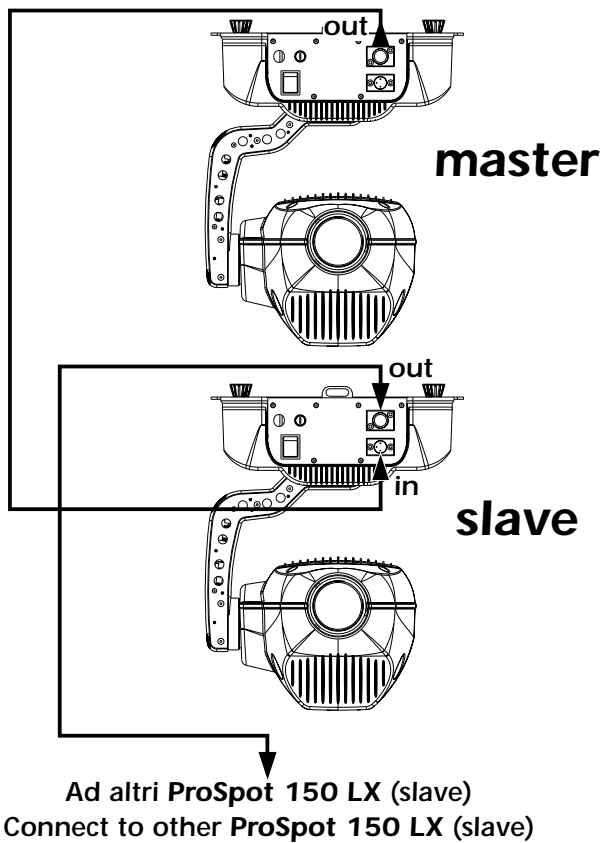

Ensure that all data conductors are isolated from one another and the metal housing of the connector.

**Note: the housing of the cannon XLR connectors being used must be isolated.**

### 8.4. Synchronising multiple ProSpot 150 LX fixtures via 6 channels of DMX

Multiple ProSpot 150 LX units may run any of the internally recorded programs, with control over step times and fade times, using 6 channels of standard DMX signal. Connection and operation is as per the normal DMX standard. The projectors must be set to operate in REM mode (see section 14 for software information).

Control signal is digital, and is transmitted via two pair screened ø0.5mm cable.

Connection is serial, up to a maximum of 32 projectors, utilising the male and female XLR 3 sockets located on the base of the ProSpot 150 LX labeled **DMX 512 In** and **OUT**.

If connecting more than 10 units, we recommend the use of a suitable opto-isolated connecting unit to amplify the signal as required. If using a controller which outputs signal via an XLR 5 (5 pin) socket, do not use pins 4 and 5, leaving them unconnected.

Pin connections conform to the international standard:

- pin 1= screening 0 volt
- pin 2= data -
- pin 3= data +
- pin 4= not connected
- pin 5= not connected

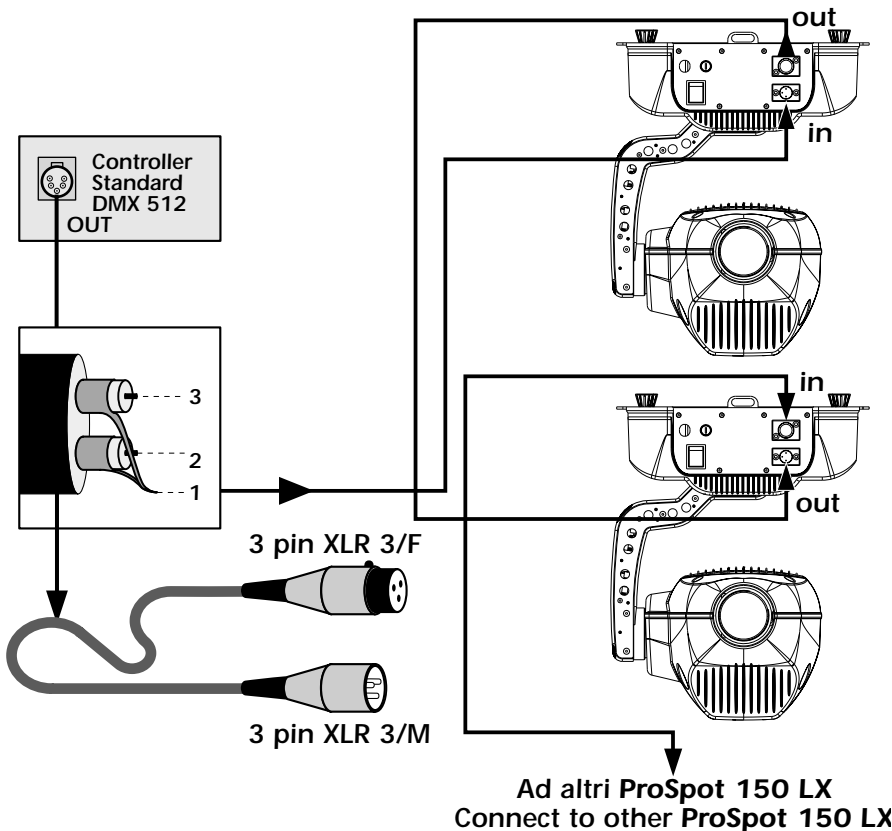

Ensure that all data conductors are isolated from one another and the metal housing of the connector.

**Note: the housing of the cannon XLR connectors being used must be isolated.**

## 9. Powering up

After having followed the preceding steps, turn on the DMX 512 controller which will be used to control the fixture and then turn on the unit via the **power** switch located on the base of the unit. The fixture will perform a reset on all the internal and external motors. This will last some few seconds, after which it will be subject to any incoming external signal.

### Software version

Two groups of software operate within the system; some in the display circuitry of the unit "D" some in the master circuitry "M". Upon powering up, the projector's LED display will briefly show the current version of software installed in the unit. For example, the ProSpot 150 LX may show:

**D1.40** (display software "D" version 2.20.

**M3.15** (master software "M" version 3.15.

### Ventilation

The projector features two fans for providing forced ventilation to the internals.

The two fans are directly under the control of the software and may be switched off depending upon what function has been selected in the display; They may not be switched off whilst the lamp is on.

To turn on the fans, you must either switch on the lamp or vary the function setting as described in section 10.2.

### DMX signal reception

After the display of software versions installed in the units two microprocessors, the projector will reset and the display will be fixed on to show that **DMX 512** is being correctly received by the projector.

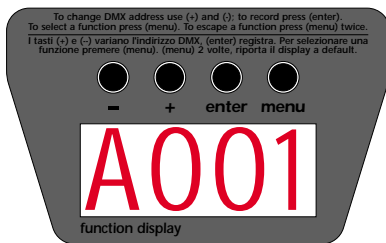

If the display flashes, the projector is not receiving signal. Check that the cabling is connected correctly and that the controller is operating properly.

### powering up with no dmx signal connected

After the display of software versions installed in the units two microprocessors, the projector will reset and the display will flash to indicate that there is no **DMX 512** signal being received.

### messages other than A001

On powering up the ProSpot 150 LX may display messages other than A001 which is the **coemar** default.

The letters and dots displayed can have the following meanings:

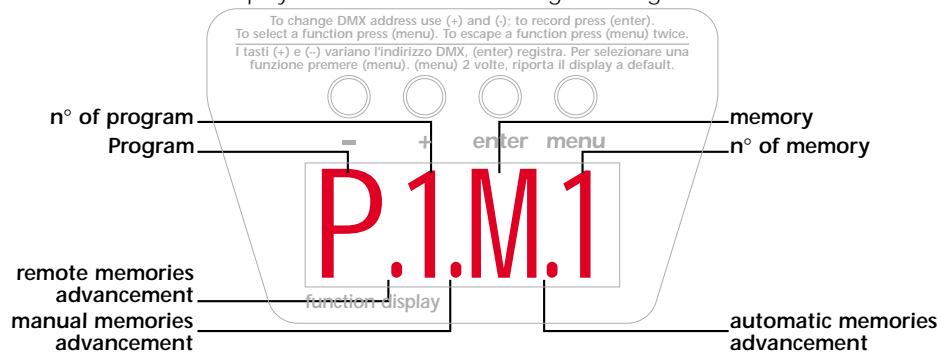

The display may indicate:

### DMX 512 address

- 1) A001 DMX 512 address 1 (for example)

### automated master/slave "solo" mode

- 2) P2.M1 master projector, program 2, scene 1, manual stepping of scene via pressing the + and - buttons.
- 3) P1M.1 master projector, program 1, scene 1, automated scene stepping
- 4) P1M1. master projector, program 1, scene 1, scene stepping in sound-to-light mode.
- 5) -SL- slave

### automated "REM" mode with control via 6 channels of DMX 512

- 6) P.1.M1 projector in remote mode, program 1, scene 1, manual stepping of scene.
- 7) P.2M.1 projector in remote mode, program 2, scene 1, automated scene stepping.
- 8) P.1M1. projector in remote mode, program 1, scene 1, scene stepping in sound-to-light mode.

The following pages indicate the other specialist settings, their description, activation and deactivation procedures.

## 10. Display panel functions

The display panel on the base of the ProSpot 150 LX is used to display and set function information and various parameters. Altering the **coemar** factory settings may vary the functioning of the projector, causing it to not respond to external **DMX 512** signal. Please read and familiarise yourself with the following information very carefully before altering any selections. NOTE: the  symbol is used in these instructions to indicate the action of pressing a button as described in the text.

### 10.1. Operating mode (MODE)

ProSpot 150 LX allows the user to select one of several operating modes:

**A001**

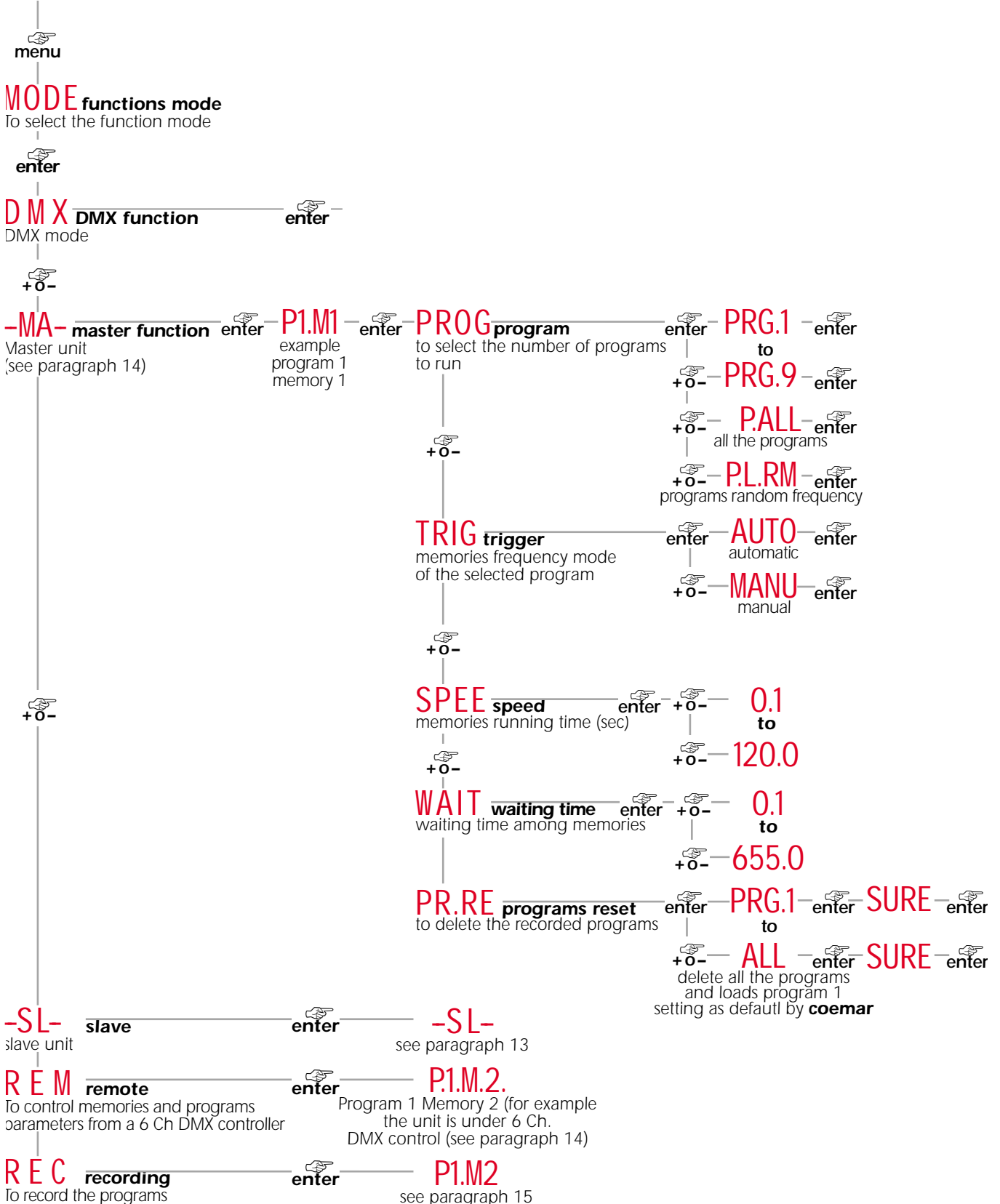

A description of these modes is located in sections 11,12,13,14 and 15 of this manual

## 10.2. Functions (FUNC)

The projector allows the altering of several functions and select personalised settings. Settings available via the "FUNC" menu are able to be altered at any time regardless of the operating mode "MODE" selected.

A001

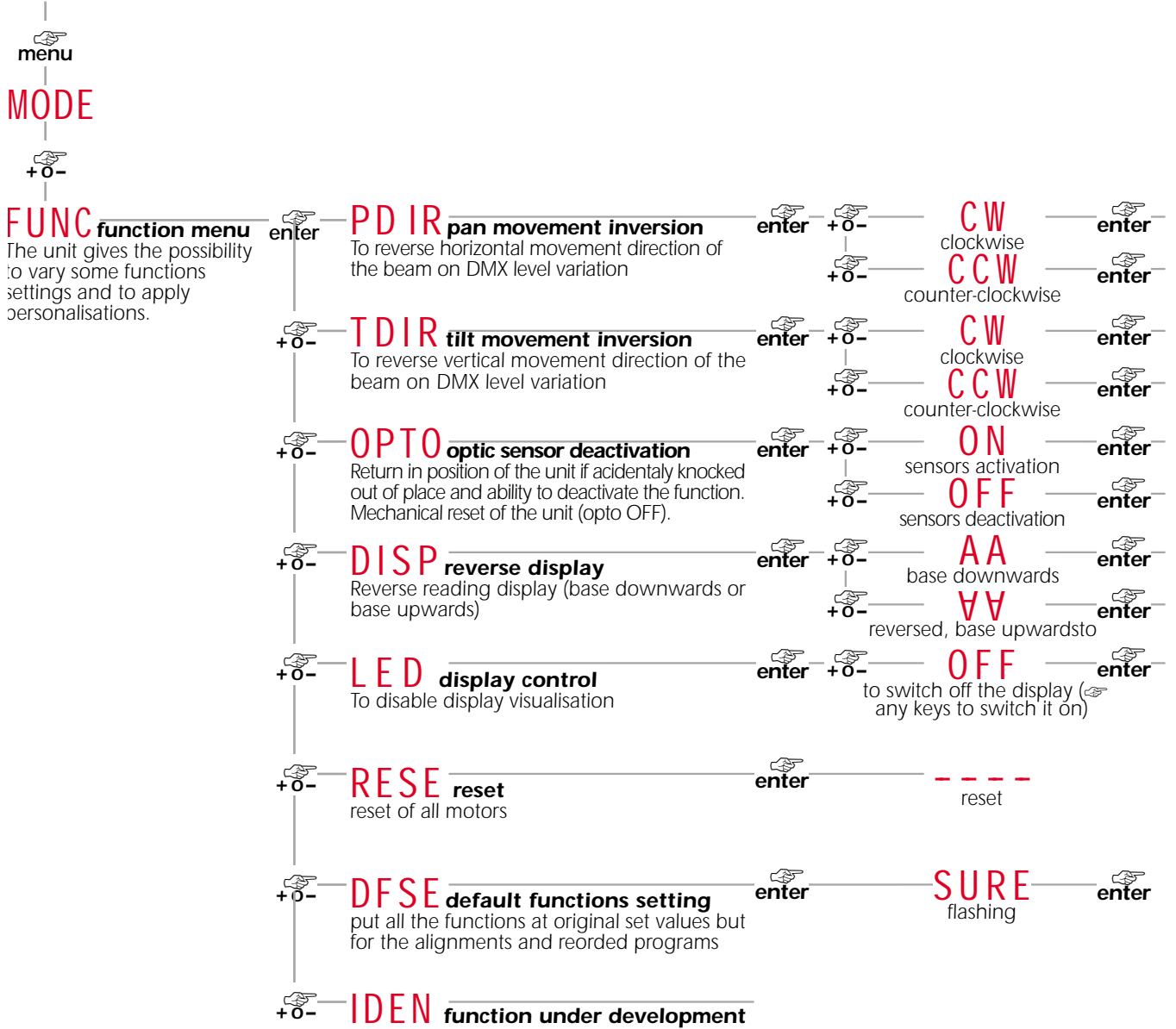

### inverted display.

As indicated above, the *i*SPOT150 allows the display in the led display panel to be inverted for ease of use should the projector be operated with its base on the ground.

The display will be inverted as shown in the following diagram (note that dots which indicate the operation of the projector in automated mode will remain in their original position and therefore will appear at the top of the display regardless of display orientation):



### 10.3. Parameters and testing (MEAS)

The internal microprocessor of the ProSpot 150 LX allows for several diagnostic and output parameters to be displayed. You may record, in this menu, the position in which the projector will come to rest when turned on with no DMX signal attached.

A001

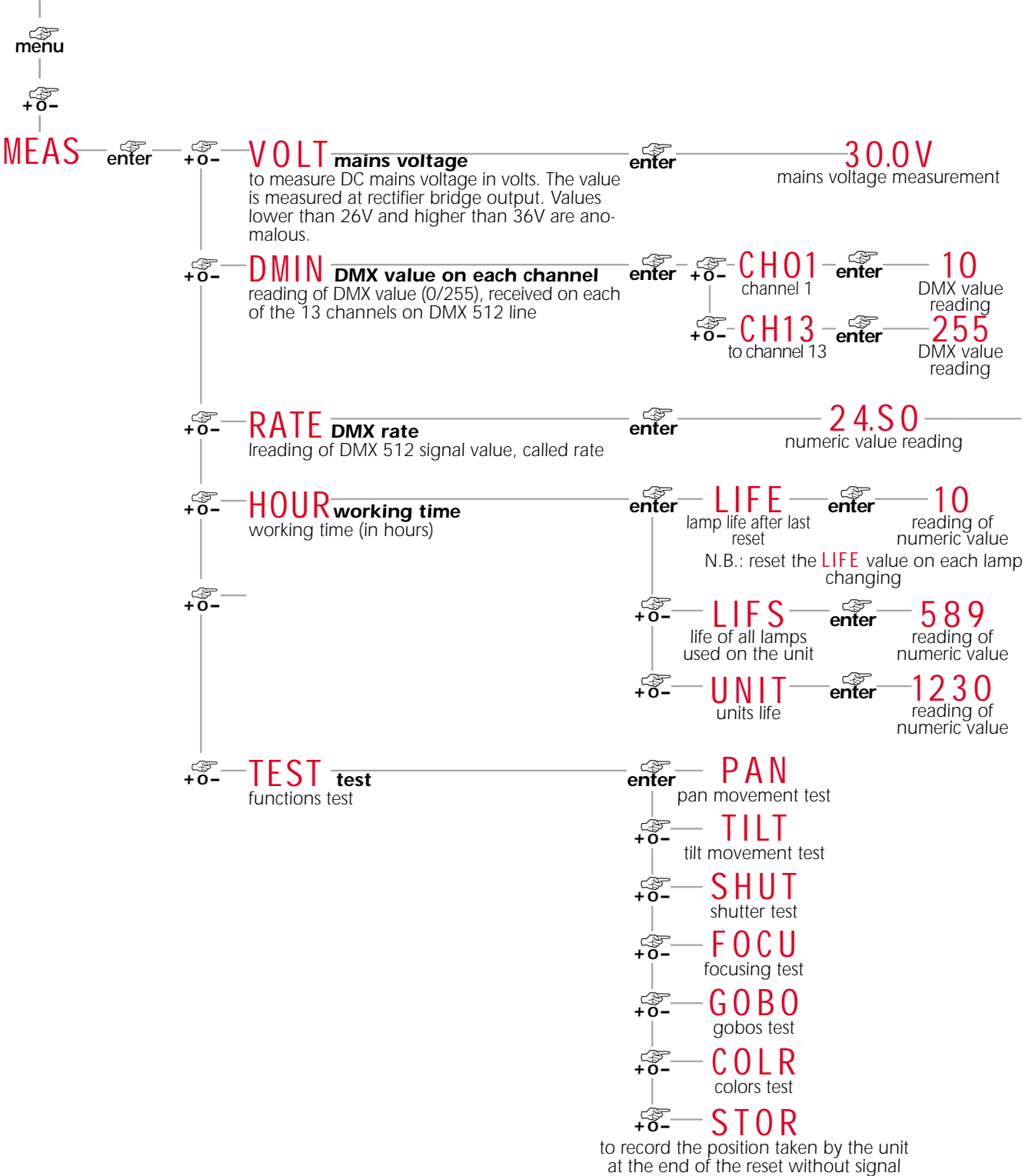

## 10.4. Quick guide to menu navigation

For your convenience, the following is a guide to navigating the menu system of the projector.

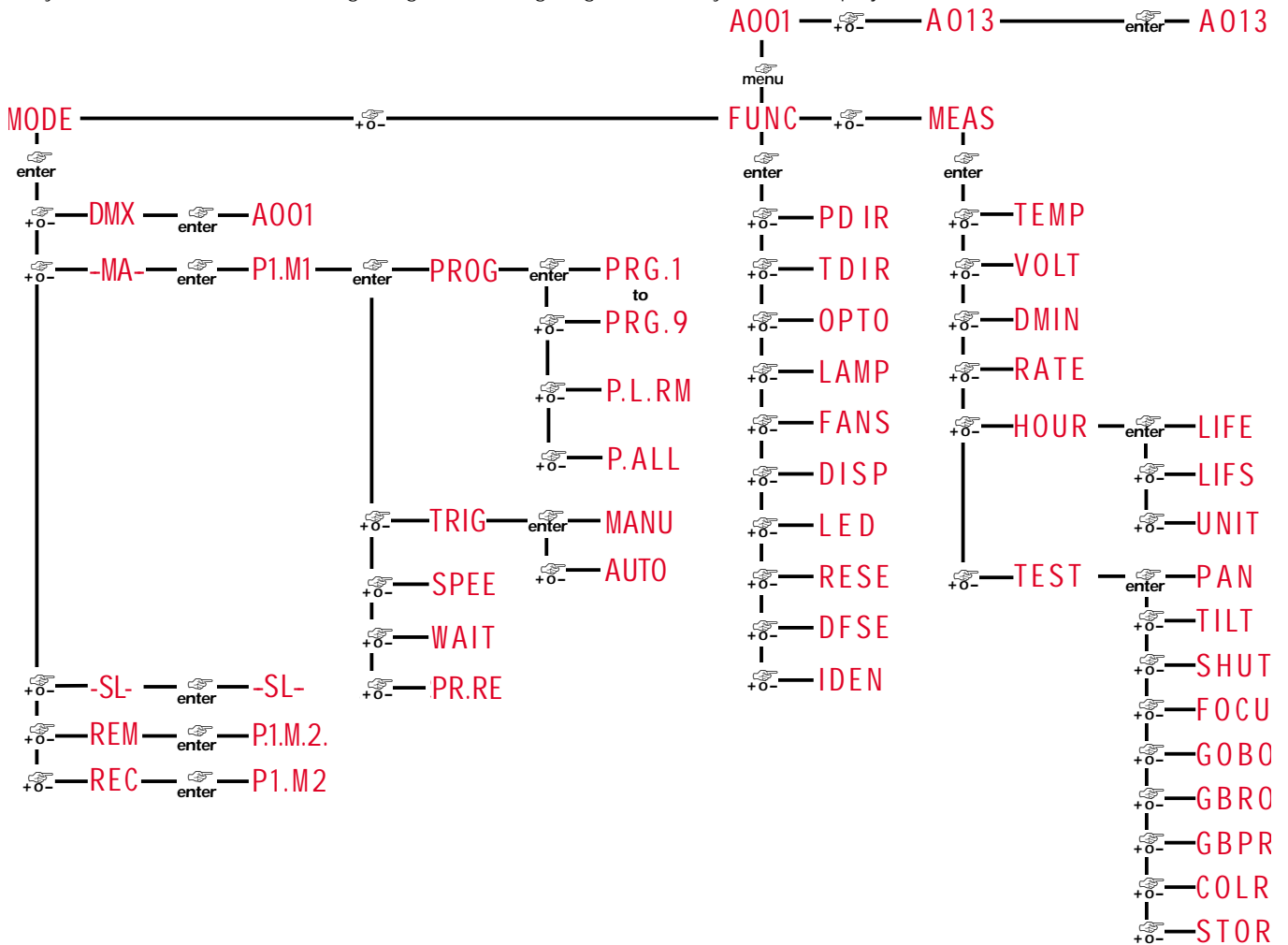

## 10.5. Rapid scrolling

Via the ProSpot 150 LX display, it is possible to rapidly scroll through the various numbers displayed in the menu which apply to the

following 3 uses:

- 1) Pressing down and holding the + or - buttons will cause the numbers to scroll more quickly than by simply pressing buttons repeatedly
- 2) Pressing down the + button and then the - button and holding them down simultaneously will cause the numbers to jump to the highest possible value available in the particular function.
- 3) Pressing down the - button and then the + button and holding them down simultaneously will cause the numbers to jump to the lowest possible value available in the particular function.

## 11. Setting the ProSpot 150 LX to operate automatically "solo"

ProSpot 150 LX may operate automatically, carrying out pre-recorded or user-created (see section 15 "Recording programs") programs

which control colour changing, gobo selection and positioning which are activated via the menu buttons.

Cables should not be connected to the XLR3 sockets of the unit, as described in section 8.1 "automated operation "solo".

- 1) Press the **menu** button, the display will show **MODE**.
- 2) Press the **enter** button, the display will show **DMX** (for dmx function).
- 3) Press the **+** button until the display shows **-MA-** (for master).
- 4) Press the **enter** button to confirm you selection; the letters **-MA-** will flash momentarily and then the display will show the program details: scene and stepping mode

The letter **P** for program with the relevant number (9 available programs, from **1** to **9** in sequence).

The letter **M** for memory (scene) with the relevant number (16 available scenes, from **1** to **9** and from **A** to **G** in sequence).

Dot positions between the characters indicate the step mode (trigger) between the scenes as follows:

**P1.M1** indicates **manual** stepping (steps between scenes are triggered by pressing the **+** or **-** buttons, with adjustable fade times)

**P1M.1** indicates **automated** stepping (steps between scenes and fade times are adjustable)

You may now alter the preset parameters:

### Altering the trigger for stepping between scenes in programs .

- 1) The display shows **P1.M1** (program 1, scene 1, manual trigger, for example).
- 2) Press the **enter** button.
- 3) Press the **+** or **-** buttons until **TRIG** is displayed (step trigger)
- 4) Press the **enter** button until the display shows the desired trigger mode.
- 5) Press the **+** or **-** button to make your selection of trigger:  
**AUTO** (automatic trigger mode, with fade time and step speed between scenes are adjustable) .  
**MANU** (manual trigger mode, with step times between scenes determined by the pressing of the **+** or **-** buttons with fade times adjustable).
- 6) Press the **enter** to confirm your selection, the display will flash and then return automatically to to the original display **P1M.1** recording the changes made, as indicated by the position of the dot in the 4 digit display.

### Altering the step speed.

- 1) The display shows **P1M1.** (program 1, scene 1, automated sound-to-light trigger, for example)
- 2) Press the **enter** button.
- 3) Press the **+** or **-** until **SPEE** is displayed (speed)
- 4) Press the **enter** button, the display will show a numerical value which corresponds to the speed of execution of the program previously selected.
- 5) Press the **+** button **-** until the desired speed is selected.
- 6) Press the **enter** button to confirm your selection, the display will flash and then return to the original display **P1M1.** recording the change made.

### Altering the fade time between steps in a program

- 1) The display shows **P1M.1** (program 1, scene 1, automated trigger, for example)
- 2) Press the **enter** button
- 3) Press the **+** or **-** button until **VAIT** is displayed (wait)
- 4) Press the **enter** button, the display will show a numerical value which corresponds to the fade time between steps in the program previously selected.
- 5) Press the **+** or **-** button until the desired fade time is selected.
- 6) Press the **enter** button to confirm your selection, the display will flash and then return to the original display **P1M.1** recording the change made.

### Selecting an alternative program to that currently running

- 1) The display shows **P1M.1** (program 1, scene 1, automated trigger, for example)
- 2) Press the **enter** button
- 3) Press the **+** or **-** button until **PROG** is displayed (program)
- 4) Press the **enter** button, the display will show the number of the program currently running **PRG.1** (for example program 1)
- 5) Press the **+** or **-** button until a new program is selected.

Note: the internal memory of the ProSpot 150 LX holds up to 9 programs. Program number 1 is recorded by **coemar**; programs 2 to 9 are recordable, as described in section 15 "Recording programs to the internal memory of the ProSpot 150 LX". ProSpot 150 LX will only allow you to select programs which contain recorded steps; empty programs will not be displayed.

- 5) Press the **+** or **-** button further and the ProSpot 150 LX will display **P.ALL** (all recorded programs played back in sequence) and **P.L.RM** (all recorded programs played back in random order).

- 6) Press the **enter** button to confirm your selection, the display will flash and return to the original display P2M1. with the output now being the newly selected program.

#### **Erasing a recorded program**

- 1) The display shows P1.M1 (program 1, scene 1, manual trigger, for example).
- 2) Press the **enter** button.
- 3) Press the **+** or **-** button until PR.RE is displayed (program reset)
- 4) Press the **enter** button, the display will show the number of the currently running program RG.1 (for example program 1)
- 5) Press the **+** or **-** button until the number of the program you wish to erase is displayed.

Note: The program recorded as described in section 15 "Recording programs to the internal memory of the ProSpot 150 LX". will be erased, and program number 1 returns to be the default. Selecting P.ALL will erase all recorded programs.

- 6) Press the **enter** button to confirm your selection, the display will seek confirmation SURE (are you sure?) and will flash.
- 7) Press the **enter** button to confirm your selection and erase the selected program; the display will return to the initial setting P1.M1..

## 12. Setting the ProSpot 150 LX to operate via DMX 512

Each **iSPOT150** utilises in standard mode, **13** channels of DMX 512 for complete control

### 12.1 DMX addressing

Before addressing the individual projectors, ensure that they have all be connected together correctly as described in section **8.2. Operation via DMX 512**

To ensure that each projector accesses the correct signal, it is necessary to correctly address each fixture. Any number between 1 and 499 can be generated via the multifunction panel of the ProSpot 150 LX. This procedure must be carried out on every ProSpot 150 LX. being used.

When powered up initially, each projector will show **A001** which indicates **DMX address 1**; a projector thus addressed will respond to commands on channels **1** to **13** from the **DMX 512** controller. A second projector should be addressed as **14**, a third as **27** and so on until the final ProSpot 150 LX, has been addressed.



If the display shows **A001** you may commence addressing the projector as required. If, however, the display shows another output (for example, program execution **P1.M1**) proceed first as follows:

**P1.M1** —  — **MODE** —  —  — **DMX** **funzione DMX** —  — **A001**  
Control mode setting through DMX signal

If the **A001** display is flashing, it would indicate that control signal is not being received correctly; check that the cable connections are correct.

#### altering dmx address

1) Press the **+** or **-** button until the display shows the **DMX** required, the characters in the display panel will flash to indicate that the selection is not stored in memory.

**A001** —  — **A014** **indirizzo DMX 14** —  — **A014**  
to select a new DMX512 address that, if not confirmed, flashes for 6 seconds before going back to default (to the address previously recorded)      The unit reacts to new DMX 512 address

2) Press the **enter** button to confirm your selection; the display will stop flashing and the projector will now respond to the new DMX address.

**Important Note:** Keeping the **+** or **-** button pressed will cause the display to alter at increased speed, allowing a faster selection to be effected.

## 12.2 DMX functions

If you have correctly followed all the steps described up to this point, your **DMX 512** controller will allow you complete control of all the functions of the ProSpot 150 LX as described in the following table.

channel	function	type of control	effect	decimal
1	<b>Base (pan) coarse</b>	proportional	coarse control of the base movement	0-255
2	<b>Base (pan) fine</b>	proportional	fine control of the base movement	0-255
3	<b>Yoke (tilt) coarse</b>	proportional	coarse control of the Yoke movement	0-255
4	<b>Yoke (tilt) fine</b>	proportional	fine control of the Yoke movement	0-255
5	<b>movement speed</b>	step	standard (fast)	0-10
		step	Ultra fast movement (best for programming position)	11-25
		proportional	vector mode from fast to slow	26-127
		proportional	Tracking mode (fast to slow)	128-247
		step	Tracking mode (slow)	248-255
6	<b>Shutter, Strobe</b>	step	Shutter closed	0-9
		proportional	Synchro strobe-effect from slow to fast	10-127
		step	Shutter open	128-130
		proportional	Random strobe-effect from slow to fast	131-248
		step	Shutter open	249-255
7	<b>focus</b>	proportional	proportional focus control	0-255
8	<b>Gobos selection</b>	step	Open	0-10
		step	gobo 1	11-30
		step	gobo 2	31-50
		step	gobo 3	51-70
		step	gobo 4	71-90
		step	gobo 5	91-110
		step	gobo 6	111-127
		proportional	From no gobo to gobo 6, 360° gobo positioning	128-192
		proportional	Gobo wheel rotation from slow to fast	193-255
9	<b>No function</b>		no function	0-255
10	<b>No function</b>		no function	0-255
11	<b>colours</b>	step	Open/white	0-5
		step	colour 1	6-13
		step	colour 2	14-20
		step	colour 3	21-27
		step	colour 4	28-34
		step	colour 5	35-41
		step	colour 6	42-48
		step	colour 7	49-59
		proportional	From white to colour 7, 360° color positioning	60-127
		proportional	Forwards rainbow effect from fast to slow	128-190
		step	No rotation	191-192
		proportional	Backwards rainbow effect from slow to fast	193-255
12	<b>gobo shake and black-out effect</b>	step	No effect	0-9
		proportional	gobo shake slow to fast 3 different amplitude sizes each	10-249
		step	Black-out while PAN,TILT moving, color or gobo changes	250-255
13	<b>motor Reset</b>	step	park, no function	0-29
		step	pan/tilt go to sensor (only once)	30-100
		step	all motor reset (only once)	101-170
		step	all motor reset except dimmer (only once)	171-240
		step	park, no function	241-255
<b>note: reset channel (13) has a delay time of 6 second to prevent accidental activation.</b>				
Fixture type: ProSpot 150 LX		Chart name: DMX 512 standard		
Chart number: 211/1		Release: 1		Date: 09/11/2001

## 13. Setting multiple ProSpot 150 LX to operate in synchronised mode without DMX 512

Multiple ProSpot 150 LX fixtures can operate in the absence of control signal by executing internally stored, pre-recorded programs. Projectors correctly connected together may operate in synchronised mode, the ProSpot 150 LX receiving signal being denominated as "slave" units and those generating control signal designated as "master" units.

To activate this automated function, projectors must be connected together as described in the section entitled "**Synchronising multiple ProSpot 150 LX fixtures without DMX signal.**" Power up the projector and use the 4 button menu system and the display panel to set the units correctly.

### 13.1 "Masters"

ProSpot 150 LX may operate automatically with output in the form of pre-recorded programs, as described in section 15 of this manual, "recording programs to the internal memory") activated by the menu and display panel.

Only **one** projector in the daisy chain, as described in section "**8.3. Synchronising multiple ProSpot 150 LX fixtures without DMX signal**" may be set up as "master."

Selecting a master unit is simply a matter of convenience and accessibility to the display panel:

- 1) Press the **menu** button, the display will indicate **MODE**.
- 2) Press the **enter** button, the display will indicate **DMX** (for dmx mode).
- 3) Press the **+** button until the display indicates **-MA-** (for master).
- 4) Press the **enter** button to confirm your selection, the **-MA-** display will flash for a few seconds, and will then show the number of the program, the scene, and the trigger method.

The letter **P** for program with the active program number (9 programs available from **1** to **9** in sequence).

The letter **M** for memory (scene) with the active scene number (16 scenes available from **1** to **9** and from **A** to **G** in sequence).

Dot positions between the characters indicate the step mode (trigger) between the scenes as follows:

**P1.M1** indicates **manual** stepping (steps between scenes are triggered by pressing the **+** or **-** buttons, with adjustable fade times)

**P1M.1** indicates **automated** stepping (steps between scenes and fade times are adjustable)

You may now alter the preset parameters:

#### Altering the trigger for stepping between scenes in programs .

- 1) The display shows **P1.M1** (program 1, scene 1, manual trigger, for example).
- 2) Press the **enter** button.
- 3) Press the **+** or **-** buttons until **TRIG** is displayed (step trigger)
- 4) Press the **enter** button until the display shows the desired trigger mode.
- 5) Press the **+** or **-** button to make your selection of trigger:  
**AUTO** (automatic trigger mode, with fade time and step speed between scenes are adjustable) .  
**MANU** (manual trigger mode, with step times between scenes determined by the pressing of the **+** or **-** buttons with fade times adjustable.
- 6) Press the **enter** button to confirm your selection, the display will flash and then return automatically to to the original display **P1M.1** recording the changes made, as indicated by the position of the dot in the 4 digit display.

#### Altering the step speed.

- 1) The display shows **P1.M1** (program 1, scene 1, manual trigger, for example)
- 2) Press the **enter** button.
- 3) Press the **+** or **-** until **SPEE** is displayed (speed)
- 4) Press the **enter** button, the display will show a numerical value which corresponds to the speed of execution of the program previously selected.
- 5) Press the **+** button - until the desired speed is selected.
- 6) Press the **enter** button to confirm your selection, the display will flash and then return to the original display **P1.M1** recording the change made.

#### Altering the fade time between steps in a program

- 1) The display shows **P1M.1** (program 1, scene 1, automated trigger, for example)
- 2) Press the **enter** button
- 3) Press the **+** or **-** button until **VAIT** is displayed (wait)
- 4) Press the **enter** button, the display will show a numerical value which corresponds to the fade time between steps in the program previously selected.
- 5) Press the **+** or **-** button until the desired fade time is selected.
- 6) Press the **enter** button to confirm your selection, the display will flash and then return to the original display **P1M.1** recording the change made.

#### Selecting an alternative program to that currently running

- 1) The display shows **P1M.1** (program 1, scene 1, automated trigger, for example)
- 2) Press the **enter** button

- 3) Press the **+** or **-** button until **PROG** is displayed (program)
  - 4) Press the **enter** button, the display will show the number of the program currently running **PRG.1** (for example program 1)
  - 5) Press the **+** or **-** button until a new program is selected.
- Note: the internal memory of the ProSpot 150 LX holds up to 9 programs. Program number 1 is recorded by **coemar**; programs 2 to 9 are recordable, as described in section 15 "Recording programs to the internal memory of the ProSpot 150 LX". ProSpot 150 LX will only allow you to select programs which contain recorded steps; empty programs will not be displayed.
- 5) Press the **+** or **-** button further and the ProSpot 150 LX will display **P.ALL** (all recorded programs played back in sequence) and **P.L.RM** (all recorded programs played back in random order).
  - 6) Press the **enter** button to confirm your selection, the display will flash and return to the original display **P3M.1** with the output now being the newly selected program.

### Erasing a recorded program

- 1) The display shows **P1.M1** (program 1, scene 1, manual trigger, for example).
  - 2) Press the **enter** button.
  - 3) Press the **+** or **-** button until **PR.RE** is displayed (program reset)
  - 4) Press the **enter** button, the display will show the number of the currently running program **PRG.1** (for example program 1)
  - 5) Press the **+** or **-** button until the number of the program you wish to erase is displayed.
- Note: The program recorded as described in section 15 "Recording programs to the internal memory of the ProSpot 150 LX". will be erased, and program number 1 returns to be the default. Selecting **P.ALL** will erase all recorded programs.
- 6) Press the **enter** button to confirm your selection, the display will seek confirmation **SURE** (are you sure?) and will flash.
  - 7) Press the **enter** button to confirm your selection and erase the selected program; the display will return to the initial setting **P1M.1**.

## 13.2 "Slaves"

All projectors which are connected to a "Master" unit should be set to "Slave". Connections should be as described in section "8.3. Synchronising multiple ProSpot 150 LX fixtures without DMX signal "

"Slave" units are recognisable since they have connections made to both XLR sockets in their base, except for the final unit in the chain which has only one connection to its "DMX IN". socket.

Once this is complete, you may proceed to set up units as "Slave".

- 1- Set the projector to "Slave" (SLAV).



When the display shows -SL- it confirms that it has recorded the setting as **Slave** and will now respond to the commands from the **master** unit.

## 14. Setting multiple ProSpot 150 LX fixtures to operate in synchronised mode using 6 channels of DMX signal

Multiple ProSpot 150 LX fixtures can execute internally stored, pre-recorded programs (see section 15 "Recording programs to the internal memory of the ProSpot 150 LX " with control over step speed and fade times controllable via 6 channels of DMX signal from a standard DMX console.

Projectors correctly connected together may operate in synchronised mode

To activate this automated function, projectors must be connected together as described in the section entitled "**Synchronising multiple ProSpot 150 LX fixtures via 6 channels of DMX signal.**" Power up the projector and use the 4 button menu system and the display panel to set dmx channel and the **REM** (remote) setting:

### setting the unit for dmx 512 control and addressing

Set the projector to operate via dmx 512 and select the dmx channel to which you wish it to respond for commands as described in section 12 "Setting the ProSpot 150 LX to operate via dmx 512 signal ".

If using the **coemar** "manual system 6" controller, set the address to "A001".

**setting the unit to "REM" remote mode**

- 1) Press the **menu** button, the display will show **MODE**.
- 2) Press the **enter** button, the display will show **DMX** (for dmx operation).
- 3) Press the **+** button until the display shows **REM** (for remote).
- 4) Press the **enter** button to confirm your selection. The figures **REM** will flash for several seconds and then will show the number of the program in memory and the type of stepping which will controlled by the 6 channels of DMX 512 signal.

After having correctly followed the above instructions, the 6 control channels will allow you to control all the functions of the ProSpot 150 LX as indicated in the following table.

<b>This mode is active only if the unit is in "REM" (remote mode)</b>				
<b>channel</b>	<b>function</b>	<b>type of control</b>	<b>effect</b>	<b>decimal</b>
<b>1</b>	<b>Program selection</b>	step	Program 1	0-22
		step	Program 2	23-45
		step	Program 3	46-68
		step	Program 4	69-91
		step	Program 5	92-114
		step	Program 6	115-137
		step	Program 7	138-160
		step	Program 8	161-183
		step	Program 9	184-206
		step	Random program	207-229
		step	ALL Programs	230-255
<b>Note: depending on channel 3 (trigger), channel 2 change functionality.</b>				
<b>2</b>	<b>Memory selection manual trigger selected on channel 3 (between 0 and 50)</b>	step	Memory 1 of the selected program	0- 9
		step	Memory 2	10-27
		step	Memory 3	28-44
		step	Memory 4	45-61
		step	Memory 5	62-78
		step	Memory 6	79-95
		step	Memory 7	96-112
		step	Memory 8	113-129
		step	Memory 9	130-146
		step	Memory A	147-163
		step	Memory B	164-180
		step	Memory C	181-197
		step	Memory D	198-214
		step	Memory E	215-231
		step	Memory F	232-248
		step	Memory G	249-255
<b>2</b>	<b>Max number of memory loop 3 (between 201 and 255)</b>	step	number of memory on master fixture	0- 14
		step	chaser stop at Memory 1	15- 29
		step	chaser stop at Memory 2	30- 44
		step	chaser stop at Memory 3	45-59
		step	chaser stop at Memory 4	60-74
		step	chaser stop at Memory 5	75-89
		step	chaser stop at Memory 6	90-104
		step	chaser stop at Memory 7	105-119
		step	chaser stop at Memory 8	120-134
		step	chaser stop at Memory 9	135-149
		step	chaser stop at memory A	150-164
		step	chaser stop at memory B	165-179
		step	chaser stop at memory C	180-194
		step	chaser stop at memory D	195-209
		step	chaser stop at memory E	210-224
		step	chaser stop at memory F	225-239
step	chaser stop at memory G	240-255		
<b>3</b>	<b>trigger</b>	step	manual mode, channel 2 for step up/down	0- 50
		step	Auto, ch. 2 limit the number of memories	51- 255
<b>4</b>	<b>step wait time</b>	proportional	from short to long	0-255
<b>5</b>	<b>movement speed</b>	proportional	from slow to fast	0-255
<b>6</b>	<b>Shutter</b>	step	Shutter closed	0- 50
		step	Shutter at programmed levels	51-200
		step	Shutter open	201- 255

## 15. Recording programs to the internal memory of the ProSpot 150 LX

ProSpot 150 LX is able to record 9 programs of up to 16 scenes each.

To record programs, the projectors must be connected as described in section 8,2 "operation via dmx 512".

Each ProSpot 150 LX utilises in standard mode **13** channels of DMX signal for the complete control of all functions. (see section 12.2); when recording programs, it utilises 17 channels, the first 13 as normal followed by 4 more which are used to record programs. You should ensure that the units to be programmed are addressed in multiples of 17 and have available a controller to program with.

### 15.1 addressing

When first turned on, projectors will be addressed as A001 indicating the address **DMX 1**; a projector thus addressed will respond to (for the purpose of programming) channels **1 to 17** of your **DMX 512** controller. The second unit should be addressed as **18**, the third as **35** and so on until the final ProSpot 150 LX.

DMX addresses can be altered as shown in section 12 of this manual.

### 15.2 DMX programming channels

Four dmx channels are utilised exclusively for programming, and these follow immediately the 13 used for normal function control. when the unit is set to "REC" mode; ensure you controller is able to address these channels:

channel	function	type of control	effect	decimal
14	Program "to be recorded" selection	step	no effect	0-9
		step	Program 1	10-37
		step	Program 2	38-65
		step	Program 3	66-93
		step	Program 4	94-121
		step	Program 5	122-149
		step	Program 6	150-177
		step	Program 7	178-205
		step	Program 8	206-233
		step	Program 9	234-255
15	Step selection	step	no effect	0-9
		step	Memory 1	10-25
		step	Memory 2	26-41
		step	Memory 3	42-57
		step	Memory 4	58-73
		step	Memory 5	74-89
		step	Memory 6	90-105
		step	Memory 7	106-121
		step	Memory 8	122-137
		step	Memory 9	138-153
		step	Memory A	154-169
		step	Memory B	170-185
		step	Memory C	186-201
		step	Memory D	202-217
		step	Memory E	218-233
		step	Memory F	234-249
step	Memory G	250-255		
16	Record enable	step	Recording mode "disabled" (FIXTURE NOT RECORDING)	0-19
		step	Recording mode "enabled" (FIXTURE RECORDING), in combination with ch 17	20-234
		step	End of recording mode, sets program length; if not used the length will always be 16 memories (in combination with ch 17)	235-255
17	ENTER	step	Enter enable, to record a memory you must change this value to 255 and then back (channel 16 must be between 20/234)	0-128
		step	Enter, store the dmx value into the selected step and program (channel 16 must be between 20/234)	129-255

coemar factory presets the units with program P.1 which can be over-written, but which remains in memory permanently and may be recalled as the default program.(see section. **11. Setting the ProSpot 150 LX to operate automatically - "Erasing a recorded program"**).

### 15.3 Programming example

- 1- Connect your dmx 512 controller to the projector using the standard DMX connector.
- 2- Ensure that the projector is correctly powered up.
- 3- Address the projectors in multiples of 17 channels, for example 1/18/35/52/69 etc.
- 4- Ensure that your controller can address all 17 channels which are required to record to the ProSpot 150 LX
- 5- Activate "REC" mode.

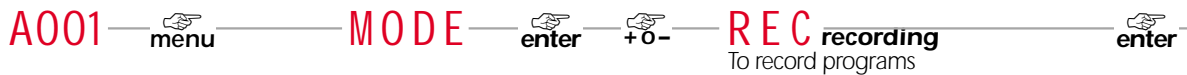

The display will show **A001 REC** (Projector 1 in record mode).

Your controller can no operate with its first 13 channels all the functions of the ProSpot 150 LX.

#### scenes

- 6- With channel 14 select the channel that you wish to record to , the projector will indicate **P2N** (program 2, no scenes recorded, for example).
- 7- Position the ProSpot 150 LX and create a scene using the first 13 channels of your controller.
- 8- Using channel 15, select the scene to which you wish to record, thus beginning the recording process, the projector will show **P2N1** (program 2, scene 1, for example).
- 9- Take channel 16 up to between 20 and 234 to commence programming.
- 10- Take channel 17 up to 255, the display will flash briefly to confirm the recording of the scene.as determined by the outputs of channels 1 to 13 of your controller to the selected program and scene.
- 11- You may record the scene to the memory of every ProSpot 150 LX in the dmx chain.
- 12- Repeat the procedure from step 7 to step 11 to record other scenes, remember to alter the scene number in succession for each new output up to a maximum of 16 scenes - which will be indicated by the number 1 to 9 followed by the letters A to G.
- 13- If you wish to record a program of less than 16 scenes, take channel 16 up to between 235 and 255 (not between 20 and 234 as previously in step 9 above) when recording the final step of the program

#### programs

- 14- Use channel 14 to select a new program when you wish to record one. The projector will show **P3N** (program 3, no scenes recorded, for example).
- 15- Repeat steps 7 to 13 above to record up to a maximum of 9 programs.

## 16. Aligning the lamp in the optical path

Aligning the lamp in the optical path is necessary to compensate for the mechanical differences amongst lamps. Since at least part of the process of manufacturing discharge lamps is manual in nature, the position of the arc may vary slightly from lamp to lamp.

The alignment process will allow for the maximum output of the lamp to be achieved.

### Alignment procedure

Alignment is effected via the three adjusters **A**, **B** and **C** operating in conjunction. Use a Philips head screwdriver for this procedure.

The three screws are located on the rear of the projector head. The adjusters act on a lever and spring assembly which position the lamp horizontally and vertically in the reflector. Rotating the screws will move the lamp within the reflector. Alignment should be effected whilst the lamp is on, the blackout fully open and no colour filters or gobos inserted. Rotate the screws until the optimum output is achieved, with both maximum output and the maximum uniformity across the beam. You should ensure that the lamp does not touch the reflector, as this could damage both components.

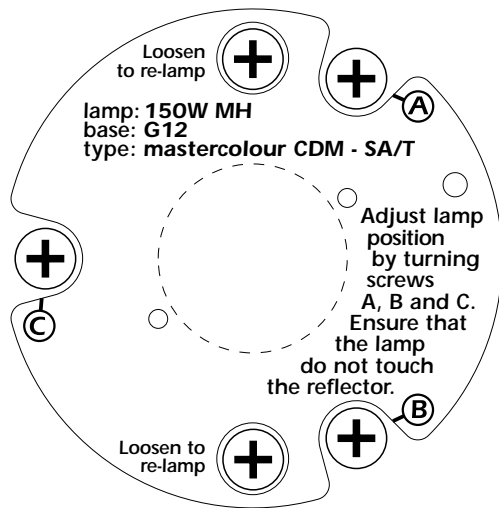

## 17. Turning on the ProSpot 150 LX without articulated movement

This function may be useful should you need to power up the ProSpot 150 LX inside its roadcase, or for any other reason where you may wish to power the unit up without it moving.

1) Power up the projector whilst simultaneously pressing the **menu**, **enter** and **-** buttons. The projector will perform the usual reset functions on every motor barring the pan and tilt motor, which will remain static throughout the reset procedure.

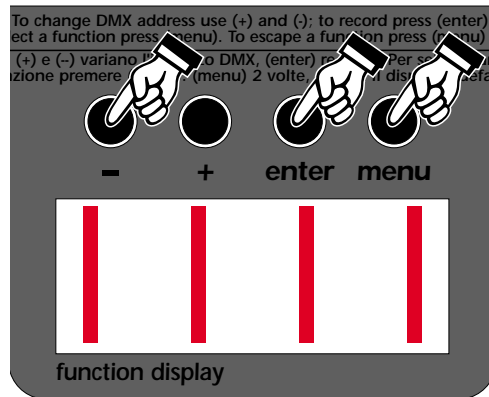

2) You may at this point alter a DMX address, or any other menu-based parameter without projector articulated movement.

3) To resume normal ProSpot 150 LX functioning, you must turn the projector off and on again via the **power** button or by effecting a reset.

## 18. Resetting the electronic counter

The electronic counter should be reset to zero hours every time the lamp is changed in order to provide accurate information about lamp life

1) Turn off the projector.

2) Power up the ProSpot 150 LX whilst holding both the **+** and **-** buttons simultaneously.

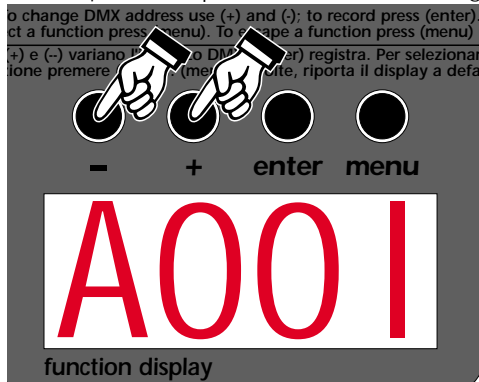

The projector will have effected a reset of the **LIFE** lamp-life counter.

To verify that the counter reset has been undertaken:

1) Press the **menu** button, the projector will show **MODE**

2) Press the **+** or **-** button until **MEAS** is displayed

3) Press the **enter** button

4) Press the **+** or **-** button until **HOUR** (for hour) is displayed.

5) Press the **enter** button

6) Press the **+** or **-** button until **LIFE** (lamp life) is displayed.

7) Press the **enter** button; the display will show **0000** confirming that the counter has been reset.

N.B. You may also verify that the other counters **LIFS** (cumulative lamp life for all lamps installed) and **UNIT** (number of hours of fixture operation) have remained unaltered.

## 19. Automatic position realignment

An internal 4 point encoder system allows the ProSpot 150 LX to return to its correct position in case the unit is accidentally knocked

out of alignment whilst operating. This is particularly useful if the projector is to be mounted on the floor in a position where the performer or artist may accidentally bump the unit.



## 20. Interchanging gobos

ProSpot 150 LX utilises a mechanical system which allows the fixtures gobos to be removed. Replacement gobos should be made of either heat-resistant glass or metal. An ever-increasing range of gobos is available from your **coemar** sales network.

### Opening the projector

1) Use a Philips head screwdriver to remove the three screws which affix the rear cover of the projector, as shown in the diagram.

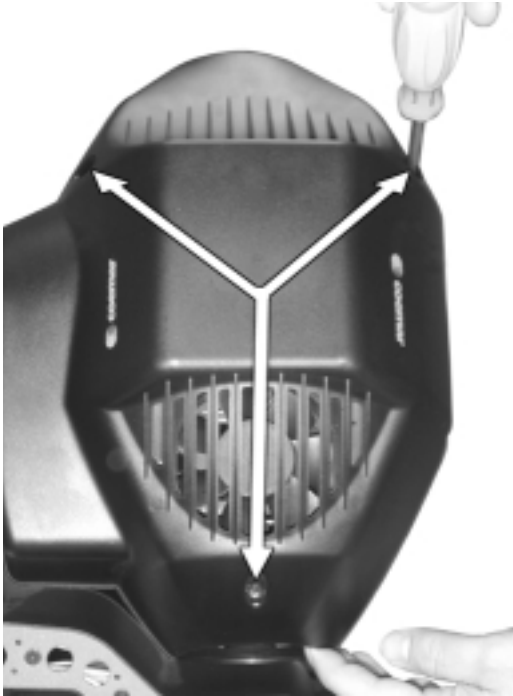

1) Remove the cover.



### Replacing gobos

Gobos may be replaced as required to produce special effects as required.

Gobo replacement should always be carried out with the power to the unit shut off and the rear cover removed as described above.

- 1) Rotate the gobo wheel until the desired gobo is visible.
- 2) Rotate the colour wheel until the empty slot of the colour wheel is lined up with the gobo selected in step 1.



- 2) Remove the retaining ring, then remove the gobo and replace as required



- 3) Replace the retaining ring making sure that it is seated correctly on the surface of the gobo.
- 4) After having replaced gobos as required, replace the ABS rear cover and refasten the screws.

## 21. Altering the operating voltage and frequency (Reserved for technical staff only)

If the factory preset operating voltage and frequency do not correspond to those in use in your country of operation, you may alter the settings as described in the following paragraphs.

**Incorrect selection of operating voltage and frequency will seriously compromise the functioning of the projector.**

### 21.1. Selecting the voltage on the autotransformer

- 1) Loosen the 4 screws on the cover of the base of the unit, as shown in the diagram below, using a Philips head screwdriver, thereby removing the cover completely and allowing access to the internal components of the base of the ProSpot 150 LX.

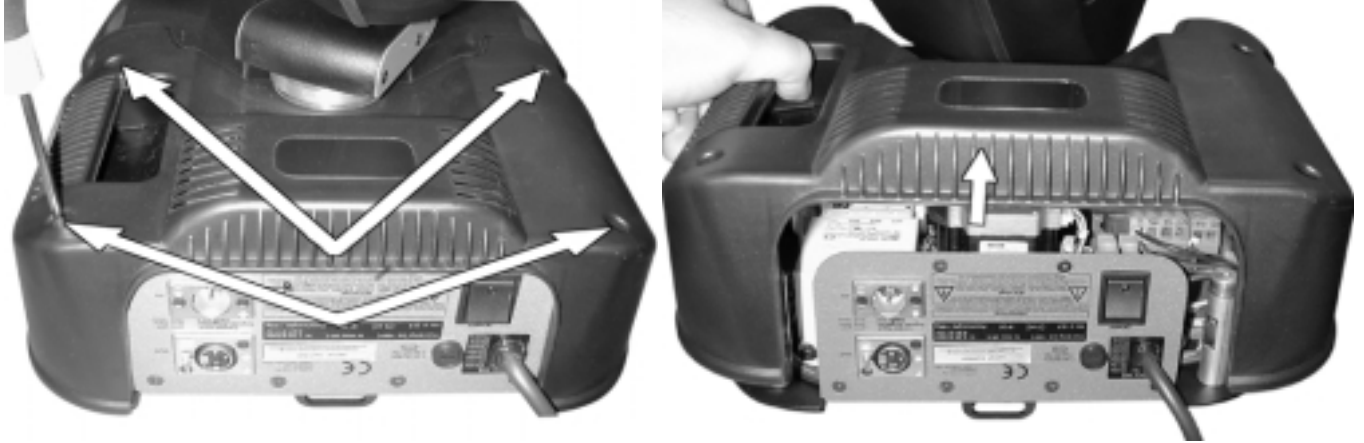

- 2) Locate the autotransformer on the right of the base.
- 3) Select a voltage from amongst 100, 115, 208, 230 and 240V by removing cable n° 7 and moving it to the required voltage. To determine which is the correct tap, refer to the sticker located on the autotransformer. Cable number 9 should not be moved under any circumstances.

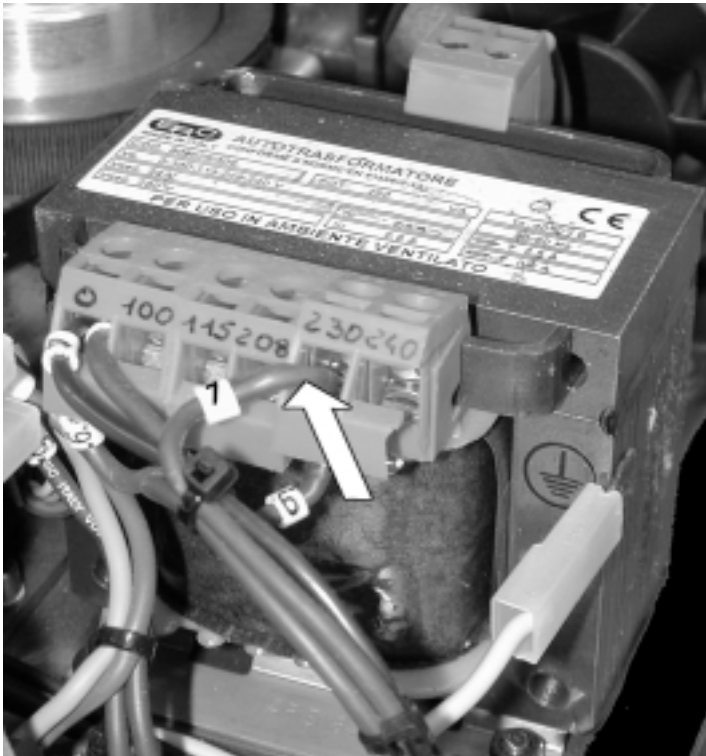

- 4) If the operating voltage selected is either 100 or 115V, replace the 3 Amps T fuse (which is suitable for 208/230/245 V operation) with one rated at 5 Amps T. The fuseholder is located in the base of the unit. The operation should be reversed should the voltages be reversed. Replacement fuses of suitable ratings were provided in the packaging of your fixture with this manual.

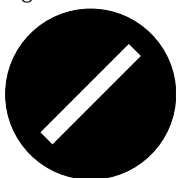

T 3A @230V  
T 5A @115V

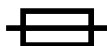

- 5) Operating frequency may now be set (if necessary) or the base cover replaced with the four screws previously removed.

### 21.2. Selecting the frequency on the power supply of the ProSpot 150 LX

- 1) Locate the power supply on the left of the base.
- 2) Select from either 50 or 60Hz by moving cable n° 11 to the required position. To ensure you have selected the correct tap, refer to the sticker located on the power supply.



- 4) Replace the base cover and fasten using the four screws previously removed.

## 22. Thermal protection

A thermal sensor in the body of the ProSpot 150 LX protects the fixture against over heating. The thermal sensor operates by removing power should the operating temperature exceed the factory preset. This may be due to several factors, including the lack of circulation around the unit, high ambient temperature, or the malfunction of an on-board fan.

## 23. Maintenance

Whilst every possible precaution has been taken to ensure the trouble-free operation of your ProSpot 150 LX, the following periodic maintenance is highly recommended. We recommend that the voltage to the unit be removed prior to any maintenance procedure taking place.

### Attention

Disconnect mains power prior to opening the inspection lid

#### Opening the projector

- 1) Using a Phillips head screwdriver, remove the three screws which affix the rear cover of the projector, as shown in the diagram.
- 2) Remove the cover.

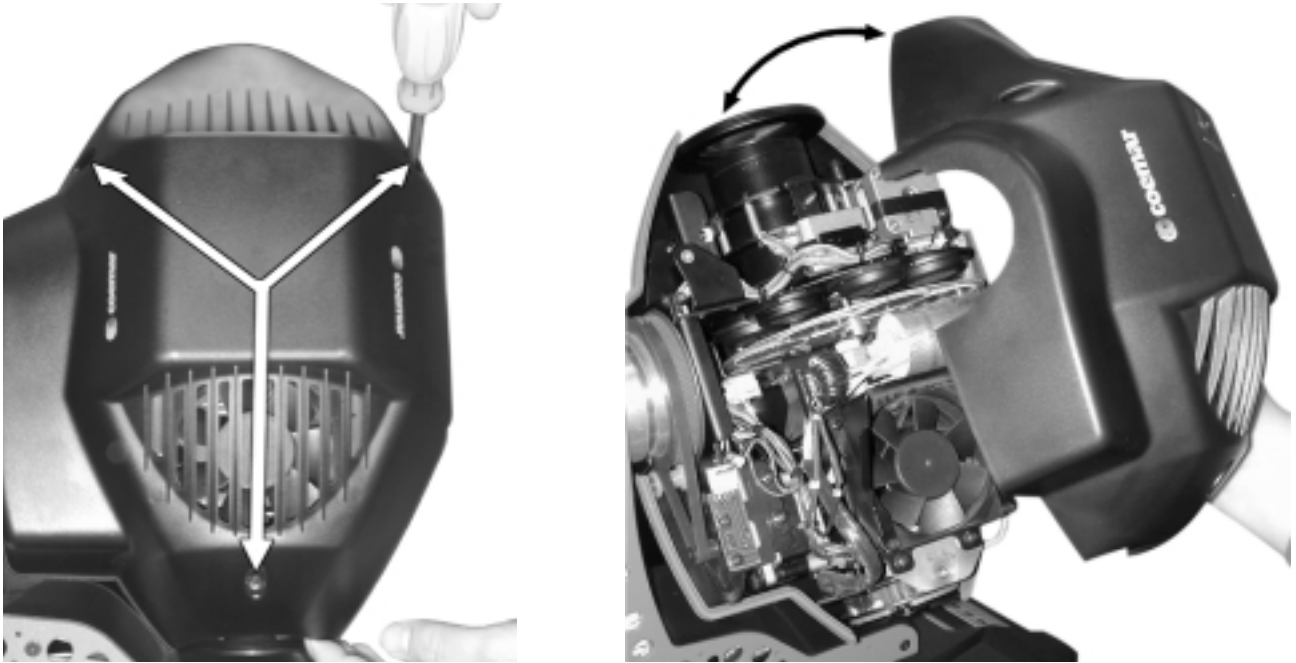

#### Replacing the fuse

Locate the three protection fuses:

Two are located on the master PCB and protect the lamp circuit and the electronics and the third is located accessible on the base of the unit protecting the entire unit.

Use a multimeter to check the fuses, replacing any faulty or damaged fuses with ones of equal value, dimensions and characteristics.

#### periodic cleaning lenses and reflectors

Even a fine layer of dust can reduce the luminous output substantially. Regularly clean all lenses and the reflector using a soft cotton cloth, dampened with a specialist lens cleaning solution.

#### fans and air passages

The fans and air passages must be cleaned approximately every 6 weeks; the period for this periodic cleaning will depend, of course, upon the conditions in which the projector is operating. Suitable instruments for performing this type of maintenance are a brush and a common vacuum cleaner or an air compressor.

#### Periodic maintenance lamp

The lamp should be replaced if there is any observable damage or deformation due to heat. This will avoid the danger of the lamp exploding.

#### mechanicals

Periodically check all mechanical devices for wear and tear; gears, guides, belts, etc., replacing them if necessary. Periodically check the lubrication of all components, particularly the parts subject to high temperatures. If necessary, lubricate with suitable lubricant, available from your **coemar** distributor.

#### electronic components

Check all electrical components for correct earthing and proper attachment of all connectors, refastening if necessary.

## 24. Electronic motor alignment

### Attention!

This section is reserved for technicians and persons with technical experience only.

The display panel on the base of the ProSpot 150 LX allows for the electronic alignment of the projector's motors. This procedure is performed by **coemar** at the factory. It may be useful to perform this procedure in the case of internal components being replaced.

Altering the factory settings may radically alter the functioning of the projector. Carefully read all of the following prior to attempting any changes.

A001

menu

MODE

+ 0 -

FUNC

enter

PDIR

+ 0 -

simultaneously during reset

RESE

reset  
motors reset

enter menu

PNAL pan  
pan motor setting

enter 0128 + 0 - es. 0120 enter

+ 0 - TLAL tilt  
tilt motor setting

enter 0128 + 0 - es. 0120 enter

+ 0 - SHAL shutter  
dimmer motor setting

enter 0128 + 0 - es. 0120 enter

+ 0 - GOAL ruota gobo  
gobos positioning motor reset

enter 0128 + 0 - es. 0140 enter

+ 0 - COAL colori  
colors rotation motor reset

enter 0128 + 0 - es. 0125 enter

+ 0 - END end  
to end setting procedure, to record  
and to go back to standard  
function mode

A001

simultaneously

+ - 0128

NOTE:

To speed up setting/alignment procedure press simultaneously + and - keys; the display will automatically go to 128

## 25 Error messages

MBER:	<p><b>COMMUNICATION Error</b> This message indicates that the motherboard within the unit is not communicating properly with the control source. Check the connectors located on both boards.</p>
OPER:	<p><b>PAN ENCODER Error</b> This message indicates that there is a problem with the PAN encoders. Check the sensors on the encoder wheel located near the pan movement motor, as well as the relevant cabling.</p>
OTER:	<p><b>TILT ENCODER Error</b> This message indicates that there is a problem with the TILT encoder locate on the fixture yoke. Check the sensors on the encoder wheel located near the pan movement motor, as well as the relevant cabling.</p>
SNER:	<p><b>LINE SYNC Error</b> Check and eventually replace opto-isolator U9.</p>
LAER:	<p><b>LAMP Error</b> The lamp has turned off unexpectedly, without any signal from the controller to do so. The system may have exceeded the allowable number of attempts to ignite the lamp (7) after which number the system is designed to protect ignitor, cabling and the lampholder by reducing the incidence of lamp ignition voltages to these components. Check and eventually replace the lamp if it is faulty, damaged, or has exceeded its lamp life.</p>
EPER:	<p><b>EEPROM Error</b> The EEPROM is either defective or absent; refer to your <b>coemar</b> service centre for a replacement component.</p>
DTER:	<p><b>DATA Error</b> The initial parameter settings are incorrect or corrupt; the projector has reloaded its factory default settings. Turn the projector off and on again. Should the error reoccur, refer the unit to your authorised <b>coemar</b> service centre to have the EEPROM check and possibly replaced.</p>
SRER:	<p><b>RESET CIRCUIT SENSOR Error</b> Check the cabling and the circuit for the RESET sensor</p>
COER:	<p><b>COLOUR WHEEL POSITION Error</b> Check the cabling and the sensor on the COLOUR wheel, the sensor and circuit board indicate an error.</p>
RGER:	<p><b>GOBO WHEEL POSITION Error</b> Check the cabling and the sensor on the GOBO wheel, the sensor and circuit board indicate an error.</p>
ER20 ÷ ER99:	<p><b>SYSTEM Error</b> Turn the unit off and on again. If the error persists, contact your authorised <b>coemar</b> service centre.</p>
HEAT:	<p><b>LAMP OVERHEAT Indicator</b> The projector is attempting to ignite a lamp, which is still too hot to strike. Wait until the lamp has cooled further and then attempt to reignite the lamp.</p>

## 26. Spare parts

All the components of the ProSpot 150 LX are available as spare parts from your **coemar** service centre. Accurate description of the fixture, model number, and type will assist us in providing for your requirements in an efficient and effective manner.